

Load-Rotors®

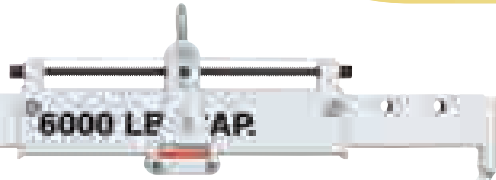

"Tilter" LR6000
2720 kg Capacity



LR2000
908 kg
Cap.



LR4000
1.816 kg
Cap.



Load-Rotors® TILTERS

908-2720 kg

- For lifting or positioning components, Power Team's heavy duty lifting slings are just right.
- The heavy-duty Load-Rotors®, when used with a crane or hoist, greatly reduce time and effort.
- A self-locking worm and gear set in the Load-Rotor® head permits rapid angle adjustment of the component being handled.
- Whenever you have big, heavy components to move or position, nothing helps you get the job done easier and faster than the 2.720 kg "Tilter."

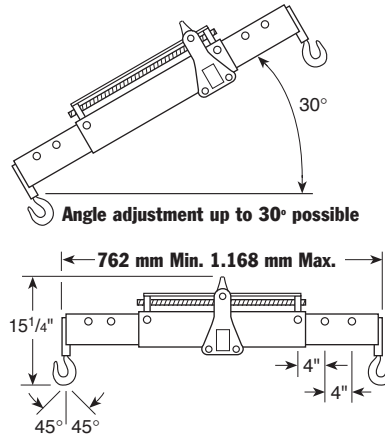

The working length is adjustable in three positions from 762 mm to 1.168 mm. Maximum chain angle is 45°.

ORDERING INFORMATION

| Capacity kg | Order No. | Chain Size (mm) | Chain Lg. W/ Swivel Hooks (mm) | Lifting Eye Opening (mm) | Hex Drive End (in) | Gear Ratio | Product Wt. (kg) |
|----------------|---------------|-----------------------|--------------------------------------|--------------------------------|--------------------------|---------------|------------------------|
| 908 | LR2000 | 6,4 | 1.422 | 31,8 | 5/8 | 34:1 | 4,1 |
| 1.816 | LR4000 | 7,9 | 1.650 | 44,5 | 5/8 | 82:1 | 10,4 |
| 2.720 | LR6000 | 7,9 | 1.650 | 41,3 | 5/8 | 82:1 | 33,1 |

SHOP EQUIPMENT